



JET TWIN

Precise, programmable batch brewer for higher volume requirements.

- > Single (6 litre) or Twin (12 litre) options
- > Pre-set recipe and volume options
- > Basket safety lock during brewing
- > Operator friendly and easy-to-use
- > Vacuum insulated urn for energy-efficiency and temperature retention
- > Two power options

JET 6 2.8KW 1000851
JET 6 5.6KW 1000850



JET TWIN
1000855



DIMENSIONS

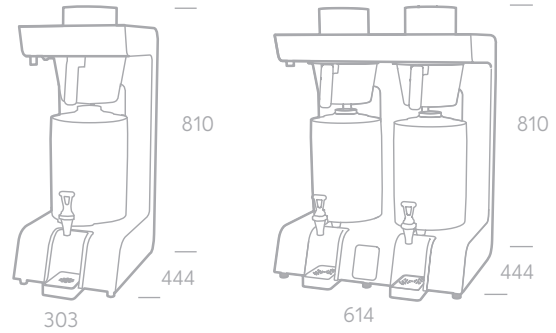

SPECS

PRODUCT INFO	PERFORMANCE SPECS	SIZE	PLUMBING & ELECTRICAL REQS		PACKAGING		
NAME ORDER CODE	FULL BREW	DIMENSIONS (D x W x H mm)	POWER @ 230V	PLUMBING REQS	PACKED WEIGHT	PACKAGING DIMENSIONS (L x W x H mm)	QTY / PALLET
Jet 6 2.8kW 1000851	6L	462 x 303 x 840	2.8kW	3/4" BSP	24kg	500 x 400 x 900	6
Jet 6 5.6kW 1000850			5.6kW				
Jet Twin 1000855	6L (per urn)	462 x 614 x 837			28kg	500 x 710 x 920	2

ASSOCIATED PRODUCTS & ACCESSORIES (SOLD SEPARATELY)

JET URN
1700204



REQUIRED

JET GRINDER
1000891



HANDS-FREE URN TAP ADAPTER
2100500

OPTIONAL



PRODUCT INFO		SIZE	PACKAGING			
NAME	ORDER CODE	DIMENSIONS (D x W x H mm)	PACKED WEIGHT	PACKAGING DIMENSIONS (L x W x H mm)	QTY / PALLET	
Jet Grinder	1000891	370 x 188 x 559	25kg	580 x 300 x 800	12	
Jet Urn	1700204	420 x 245 x 570	7kg	640 x 310 x 440	16	
Hands-Free Urn Tap Adapter	2100500	—	—	—	—	
Jet Filter Papers - Case of 500	8000151	—	—	—	—	

JET TWIN BATCH BREWER

JET TWIN 1000855

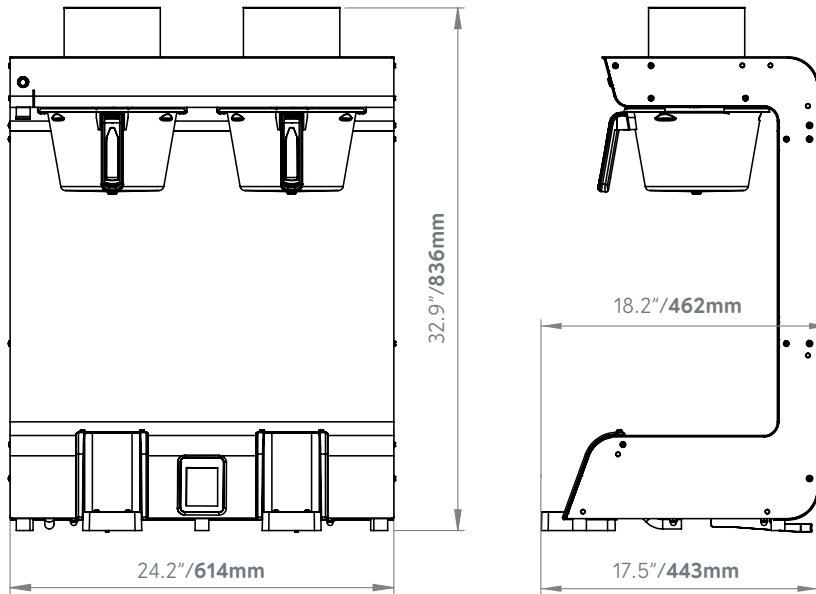

VENTILATION REQUIREMENTS

- > Back: 70mm/2.7"
- > Sides: 50mm/1.9"

Clearance required around machine if installed in an enclosed cabinet.

ELECTRICAL INSTALLATION PROCEDURE

When installing the machine, always observe the local regulations and standards. The 5.6kW machine is supplied with a three core electrical cord and should be connected to a 30 amp dedicated socket. For EU models a 2-pin CEE-7 plug will be supplied. US models will be supplied with the suitable plug. A suitable mains power supply socket should be available within easy access of the appliance so that it can be disconnected easily after install.

PLUMBING INSTALLATION PROCEDURE

- > Ensure that the equipment is installed according to local plumbing & water regulations.
- > Fit a stop valve and suitable fitting on a cold water line (e.g. 3/4" x 1/2" 311 or washing machine type stop valve).
- > The boiler requires a suitable food grade inlet hose with 3/4" BSP female elbow fitting which will attach to the underside of the machine.

- > Make sure that the pre-attached sealing washer is fitted on both ends.
- > Turn on the water to flush any impurities, dust etc. from the inlet hose and water pipe. Allow several gallons through.
- > Connect right-angled tailpiece of the hose to the inlet valve of the boiler (again 3/4" BSP). Make sure the sealing washer is fitted here again.
- > Turn on water and check for leaks.

NOTE: Using a non-food grade hose (e.g. a washing machine hose) will usually result in off-tastes & smells in the water, and can possibly be toxic.

OPERATING THE APPLIANCE FOR THE FIRST TIME

- > Check that all installation procedures have been carried out.
- > Ensure the water valve is on. Plug the machine into an appropriate electrical supply and switch on the rocker switch under the machine. Follow the instructions on the screen.