

Instruction Manual
Machine P/N: 1000050#, 1000051#, 1001050US, 1001051US

FRIIA

Contents

Introduction.....3

1.Specification.....4

Installation requirements.....4

2.Safety.....4

3. Basic Installation.....7

ChillerInstallation.....7

CO2Installation.....8

4.Operation.....9

5. Sanitization and Cleaning.....11

6. Troubleshooting.....12

7. FRIIA Installation Guide.....13

Box Contents

FRIIA Cold/Carbonated	Part no.
Chiller 230Vac - 50/60Hz	1000050
Chiller 115Vac - 60Hz	1001050US
Chiller to Boiler Cable	1501180
1m length 3/8" Tube (water)	1800627
1m length 6mm Tube (CO2)	1800628
User Manual	n/a

FRIIA Cold	Part no.
Chiller 230Vac-50/60Hz	1000051
Chiller 115Vac-60Hz	1001051US
Chiller to Boiler Cable	1501180
1m length 3/8" Tube (water)	1800627
User Manual	n/a

It is highly recommended to fit a water regulator to the supply feed. In the event of mechanical failure a regulator set correctly will ensure the water supply is cut. Marco suggests 10 litres continuous flow.

Accessories

Part no.	Description
1600860#	FRIIA Fan Assembly (Wall Socket)
1600861	FRIIA Fan Assembly (Chiller Socket)

Introduction

The information provided in this manual is intended to assist in the installation and maintenance of the Marco FRIIA System. Please read the instructions carefully to prevent accidents and ensure an efficient installation. This manual is not a substitute for any safety instructions or technical data affixed to the machine or its packaging. All information in this manual is current at the time of publication and is subject to change without notice. Only technicians or service providers authorised by Marco should carry out installation and maintenance of these machines. Marco accepts no responsibility for any damage or injury caused by incorrect or unreasonable installation and operation. Do not allow anyone to operate the equipment unless suitably trained. Keep the equipment in good working order and do not allow any modifications unless authorised by the manufacturer.

RATING PLATE

A	MODEL: 1000050 FRIIA Cold Sparkling 230V		F
B	SERIAL NO: 0123456789		
C	230V 50/60Hz 380W		
D	Refrigerant : R290 70g (2.47oz)		
	Pressure : Low 383kPa High 1676kPa		
	WATER INLET PRESSURE MIN-MAX		G
E	0.1-1MPa (14.5-145psi)		
	MARCO BEVERAGE SYSTEMS LTD.		
	www.marco.ie		

- A. Model Number and name.
 - B. Product serial code (mmyyxxxxxx)
 - C. Rated Voltage.
 - D. Rated Power.
 - E. Contact details.
 - F. WEEE Logo
 - G. This logo indicates that the product must not be disposed of as household waste. To help prevent possible harm to human health and/or the environment, the product must be disposed of in an approved and environmentally safe recycling process. For further information on how to dispose of this product correctly, contact product supplier, or the local authority responsible for waste disposal in your area.
- G. Regulatory standard logo
This equipment has been designed and tested to comply with all applicable regulatory standards set by international, independent and government authorities.

<p>WARNING:</p> <p>The refrigerant R290 (Propane) is flammable and it must be handled only by competent and responsible operators, under the conditions specified in the safety regulations in force.</p>	
---	--



1. Chiller Specification

Safe operating temperature:	N from +16 ° C to +32 ° C (standard class)
Cooling system:	Aluminium black heat exchanger.
Colling capacity:	35–40 litres/hour.
Electrical requirements:	Two 13 amp sockets operating on 230V single phase.
EU version bifrequency	
Voltage and frequency ratings	230V / 50Hz
Max power consumption (chiller):	380W, 1.6A
US version	
Voltage and frequency ratings	120V / 60Hz
Max power consumption (chiller):	tbd W tbd A
Compressor nominal power:	1/8 HP.
Refrigerant type and quantity:	R290 / 70g
Carbonator volume (just for SW versions):	1ltr.
Net Weight:	35kg.
Noise level	Does not exceed 70dB

1.1 INSTALLATION REQUIREMENTS (See also Basic Installation p7, Installation Guide p13)

Mains water pressure required downstream of any filter systems:	22 – 140psi (150 – 1000kPa) (1.5 – 10 bar)
If mains pressure is below 1 bar or the flow rate is less than 2L/min:	fit a device capable of increasing the mains pressure (autoclave or similar). ensure your water net is able to supply at least 2L/min water flowrate.
Water connection:	3/8" Quick connection fitting.
Electrical requirements 230V:	Two 13 amp sockets operating on 230V single phase.
Electrical requirements 120V:	Two 15 amp sockets operating at 120V
Machine location:	The machine must be located in a well ventilated space, at least 10cm (3.9inch) around back and top for ventilation.

2. Safety

2.1 IMPROPER USE

This equipment is deisgned solely for the use and conditions as outlined in this manual. The use of this equipment for any other purpose is not permitted in any circumstance.

This unit can be used by adults without any experience and knowledge under supervision or after instruction on the safe use of the equipment and have understood the risks. Children should not operate the equipment. Installation cleaning and user maintenance must not be carried out by children.

This equipment is not intended to be used by people (including children) with reduced physical or sensory capacities or with a lack of experience and knowledge, unless under supervisor or instructed by someone responsible for their safety. For safety reasons, and in accordance with the current legislation, any repair operations on the equipment must be carried out by the Service Centre.

- Do not alter or tamper with the internal dispenser components; if they are not operating properly contact the Service Centre.
- Do not place anything on top of the Boiler or Chiller
- Do not run any other liquid besides water through the system.
- If you believe the system to be damaged, contact Marco Beverage systems.
-

If the inlet hose is damaged, it must be replaced with a new inlet hose–set compliant to EN 61770 or IEC 61770.

2.2 SYMBOLS USED IN THE MANUAL

This manual uses the following safety symbols to draw the operator's attention to all operations which must be strictly observed in order to prevent injury to persons or damage to the equipment.



DANGER

Shows the existence, on or around the equipment, of a real risk of death or severe injury for the operator and other persons; it is therefore essential to take the greatest care and proceed with the greatest caution.



WARNING

Shows the existence, on or around the equipment, of a potential risk of death or severe injury for the operator or other persons; it is therefore essential to take great care and proceed with the greatest caution.



CAUTION

Shows the existence, on or around the equipment, of a potential risk of minor injury for the operator or other persons; it is therefore essential to take great care and proceed with the greatest caution.

2.3 LIST OF HAZARDS

The following list of hazards draws attention to safety aspects which must be considered at all times by anyone using the equipment.



DANGER

CO₂ (CARBON DIOXIDE)

CO₂ cylinders must always be stored in a well-ventilated place where the air can flow in and out. Great care must be taken to prevent CO₂ leaks throughout the system, including the gas cylinders.

If a CO₂ leak is suspected, especially in a small area, ventilate the contaminated area at once, persons exposed to high concentrations of CO₂ will experience trembling, swiftly followed by unconsciousness and suffocation.



DANGER

ELECTRICAL MAINS

Always disconnect the equipment from the electricity supply before carrying out any work, to prevent damage and health hazards.



DANGER

GAS CYLINDER LOCATION

To prevent the risk of injury or damage, the CO₂ cylinder must always be kept in a vertical position against a wall, held in place by a chain fixed to a bracket. Do not expose the bottle to heat sources or very low temperatures.

Only super-dry food grade CO₂ should be used.

Before connecting the pressure reducer to the gas cylinder, always vent any dirt from the valve, and close the cylinder valve after few seconds



DANGER

Keep the ventilation openings on the equipment and on the cabinet in which the system is installed free from obstruction.



DANGER

AUTHORIZED TECHNICAL STAFF

The refrigerant R290 (Propane) is flammable and it must be handled only by competent and responsible operators, under the conditions specified in the safety regulations in force.



CAUTION

ELECTRICAL REQUIREMENTS

The electrical circuit must be correctly earthed and connected by means of a suitable differential safety breaker.



CAUTION

REPLACEMENT OF THE POWER CABLE

If the power cable is damaged, it must be replaced by the manufacturer or their assistance service or a similarly qualified person in order to prevent any possible risk.



CAUTION

LOW TEMPERATURE

If the equipment is exposed to temperatures lower than 0°C, the water inside could turn to ice and damage the equipment.



CAUTION

SANITISATION

Before sanitising the equipment, carefully read the instructions given by the sanitisation product manufacturer and put on all the necessary personal protective equipment (gloves, masks, etc.).

Ensure that the premises are well ventilated.

The sanitisation operations should only be carried out by specialised technical assistance personnel.



DANGER

ELECTRICAL MAINS

Always disconnect the equipment from the electricity supply before doing any work on it, to prevent damage and health hazards.



CAUTION

ELECTRICAL REQUIREMENTS

The electrical circuit must be correctly earthed and connected by means of a suitable differential safety breaker.



CAUTION

ELECTRIC POWER SUPPLY

Do not connect or disconnect the machine from the socket with wet hands.

Insert the plug into the wall socket firmly.

Do not pull on the supply cable in order to remove the plug from the socket.



CAUTION

REPLACEMENT OF THE POWER CABLE

If the power cable is damaged, it must be replaced by the manufacturer or their assistance service or a similarly qualified person in order to prevent any possible risk.



WARNING

MALFUNCTION

If smoke, unusual smells or strange noises are emitted from the machine, disconnect it immediately from the socket and contact the local retailer or technical service assistance.

Use of the machine in these conditions could cause fires or electric shocks.



ATTENTION

If the equipment is installed in a kitchen, European Standard EN 60335-2/75 specifies that it must be connected to an equipotential circuit via a wire with section between 2,5 and 10 mm². This connection must be carried-out by a skilled technician, in compliance with the regulation in force in the country of use.



WARNING

WATER SUPPLY

Connect the water dispenser exclusively to a line of drinkable water supply.



WARNING

WATER SUPPLY

In order to avoid accidental flooding due to losses that may occur on the water supply line, external or internal device it is necessary to install the appropriate anti-flooding valve "WATER BLOCK" (not included in the unit).



DANGER

CO₂ (CARBON DIOXIDE)

CO₂ cylinders must always be stored in a well-ventilated place where the air can flow in and out. Great care must be taken to prevent CO₂ leaks throughout the system, including the gas cylinders.

If a CO₂ leak is suspected, especially in a small area, ventilate the contaminated area at once, persons exposed to high concentrations of CO₂ will experience trembling, swiftly followed by unconsciousness and suffocation.



DANGER

Do not use or store cylinders of CO₂ at temperatures above 35°C.

Do not use or store cylinders of CO₂ inside the appliance.



DANGER
PRESSURE REDUCER
Never connect CO2 cylinder directly to the equipment. Always use a suitable pressure reducer.



DANGER
GAS CYLINDER LOCATION
To prevent the risk of injury or damage, the CO2 cylinder must always be kept in a vertical position against a wall, held in place by a chain fixed to a bracket. Do not expose the bottle to heat sources or very low temperatures. Only super-dry food grade CO2 should be used.
Before connecting the pressure reducer to the gas cylinder, always vent any dirt from the valve, and close the cylinder valve after few seconds.



DANGER
ELECTRICAL MAINS
Always isolate chiller from power supply before doing any work on it, to prevent damage and health hazards.



CAUTION
Before carrying out the following operations, carefully read the instructions given by the sanitization product manufacturer and make sure all personal protective equipment (gloves, masks, etc.) is worn correctly. The sanitization of the product lines must only be carried out by specialized technical service personnel. During the sanitization operations, attach a warning sign to the tower concerned, to inform any other personnel that this operation is in progress, and that it is forbidden to dispense beverages.



DANGER
ELECTRICAL MAINS
Always isolate chiller from power supply before doing any work on it, to prevent damage and health hazards.



ATTENTION
Do not spray water on the device; this could cause electric shocks or fires.

3. Basic Installation (See also Installation Guide p13)

3.1 UNPACKING INSTRUCTIONS

- The chiller must be handled only in a vertical position. Transporting the appliance in a horizontal position can cause severe damage to the refrigerator.
- Remove the exterior and interior packing. Packing materials (especially any plastic bags) should be stored out of the reach of children, as a potential source of danger. When disposing packaging parts, please follow current regulations on the matter, separating carton from plastic parts.
- Always check that the equipment that is delivered corresponds to the model indicated in the accompanying document.
- The equipment is shipped in a cardboard box. Once the packaging has been removed, check the equipment has not been damaged in transit; if damage is found, notify the carrier.

3.2 ELECTRICAL INSTALLATION PROCEDURE

FOR EUROPEAN AND US VERSION

When installing the machine, always observe the local regulations and standards. The appliance is supplied with a moulded power cord. A suitable mains power supply socket should be available within easy access of the appliance so that it can be disconnected easily after install.

FOR JAPANESE VERSION ONLY:

A suitable mains power supply junction box should be available within easy access of the appliance so that it can be disconnected easily after install.:

No power cord is supplied with the machine : use a Japanese approved power cord with the following characteristics

a) Machine side: Japan PSE Approved IEC C13 Connector (JIS C8303).

b) Power cable : JIS C 3306 approved.Polyvinyl Chloride Insulated Flexible Cords type VCTF/HWCTF and section higher than 3 x 0,75 mm², with wires to be connected in the wall mounted junction box.

When installing the machine, always observe the local regulations and standards.

3.3 PLUMBING INSTALLATION PROCEDURE

- Ensure that the equipment is installed according to local plumbing & water regulations.
- Fit a stop valve on a cold water line and attach a 3/8" BSP male fitting, (E.g. 3/4" x 1/2" 311 or washing machine type stop valve).
- Connect water supply lines following the installation drawings. As per installation guide (starting page 14)
- In case filter systems are used verify that they satisfy the requirements of the legislation in force.
- If the filter is new, turn on water and flush at least 10 liters (2.5 gallon) through the filter before to connect it to the cooler; if the filter is a used one, connect water inlet to the chiller.
- To ensure that the maximum value of pressure of 3 Bar is not exceeded the chiller integrates a pressure reducer.
- Turn on the water to flush any impurities, dust etc from the inlet hose and water pipe. Allow several litres through. Especially for new installations.

3.4 CO2 INSTALLATION PROCEDURES

Connect CO2 using the appropriate polyethylene tube.

CO2.

- Only use super-dry food grade CO2 should be used. Before connecting the pressure reducer to the gas cylinder, always vent any dirt from the valve and close the cylinder valve after few seconds.

GAS CYLINDER LOCATION

- To prevent the risk of injury or damage, the CO2 cylinder must always be kept in a vertical position against a wall, held in place by a chain and fixed to a bracket. Do not expose the bottle to heat sources or very low temperatures.

PRESSURE REDUCERS

- There are different type of CO2 cylinder available. Always use a pressure reducer suitable for the type of valve on the cylinder.
- If you use CO2, especially in a small area, ventilate the contaminated area at once.
- Please use Dual gauge CO2 regulator 1400195
- Check for leaks using a solution of soapy water.

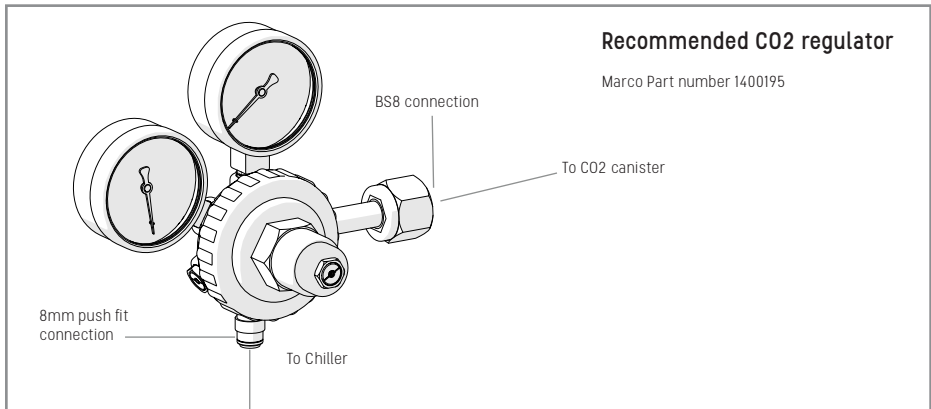

3.5 BACKFLOW PREVENTION

This equipment must be installed with adequate backflow protection to comply with all applicable federal, state and local codes.

3.6 ENVIRONMENTAL CONDITION

- The equipment is not suitable for external use.
- The equipment must be placed so it is protected from rain and water splashes, and in a location with the temperature appropriate to its climate class (stated in specification); otherwise warranty rights are forfeited and malfunctions may occur.

3.7 POSITIONING

- The equipment must be placed on a surface capable of bearing the weight of the dispenser complete with water. Install the equipment following the schematic described in this user guide.
- The chosen position must in any case allow satisfactory ventilation; in particular, there must be a gap of at least 10 cm (3.9 in) around the back and top for ventilation.
- The equipment must not be placed close to direct or indirect heat sources (ovens, stoves, radiators, etc.). The electrical connection and water supply points must be close to the equipment and located in such a way the power cable and water hose do not form an obstruction.
- The appliance must not be installed where water jets can be generated. Do not spray water on the device; this could cause electric shock or fires.

4. OPERATING

4.1 BEFORE USING CHILLER

- Before connecting the appliance to the power source, let it stand upright for approximately 2 hours. This will reduce the possibility of a malfunction.
- Check that all installation procedures have been carried out. (section 7)
- Ensure water inlet is open.
- Ensure CO2 valve is open
- Before supplying power to the unit check water and Carbon Dioxide lines do not leak.
- Plug the chiller into a suitable socket and switch ON/OFF switch on the rear of the chiller to ON position.
- Plug the boiler into a separate suitable socket and switch ON/OFF switch on the rear of the boiler to ON position.
- The "Power ON Status" light will light-up.
- Set the boiler to UC single (page 21)
- When the unit is on, the carbonation pump starts to fill. The carbonation device stops when it reaches the maximum level.
- Open the PRV vent on top of the Chiller by pulling the ring. This operation allows the escape of any air bubbles present inside, which would affect the carbonation adversely.
- On the pressure reducer knob, adjust CO2 pressure to a value between 50 and 65 PSI (350 and 450 kPa) (3.5 – 4.5 bar) This value depends on the temperature of the water and on the ambient temperature. The temperatures correspond to the CO2 pressure.
- To enable the filling of lines, push the front buttons in the following order sparkling water, Cold water & hot water until the flows appear.
- At this point you can dispense water.

CARBONATION PUMP

The device is equipped with a carbonation pump required for the addition of Carbon Dioxide in the water. After about 3.5 minutes of continuous operation, without the usual stops and starts dictated by the carbonation level probes (obvious symptom of leak of water in the feed), the pump shuts carbonation and LED if provided, starts blinking. To reset this simply disconnect and then reconnect the power to the equipment.

THERMOSTAT SETTING

The temperature on FRIIA is preset to the optimal setting. If you require temperature adjustment please contact the Marco service team.

Tel: 00353 (0) 1 295 2674
Email: marco.service@marco.ie

4.2 MAINTENANCE

Maintenance procedures (described below) are required for optimum equipment operation.

4.2.1 DAILY MAINTENANCE

1. Water faucet. Clean the faucet nozzle and remove any residue using warm water; do not use solvents or abrasive detergents. If required, remove all the limestone with a food descaling solution.
2. Drip tray. Clean the tray and remove any residue using warm water.
3. CO₂ pressure. Review pressure CO₂ gauges for proper settings.
4. Power cord. Check condition of the power cord. Replace if necessary.

4.2.2 LIMESCALE

Descaling of the machine should ideally be carried out by qualified service personnel.

4.2.3 CHECK FOR CO₂ PRESSURE:

Review pressure CO₂ gauges for proper settings. 50 – 65 psi (350 – 450 Kpi) (3–4.5 bar).

Replacing a carbon dioxide (CO₂) cylinder.

The cylinder must be replaced when the needle of the reducer high pressure gauge is in the red segment.

1. Record the pressure values set on the pressure reducer, then fully close the bottle with the valve.
2. Remove the pressure reducer or disconnect the high pressure hose from the bottle if fitted. Check the condition of the gaskets between the reducer and the bottle, replace them if necessary.
3. Replace the CO₂ cylinder by slowly opening the valve to the fully open position and check that the pressure values are as originally set.

4.2.4 CLEANING THE CHILLER CONDENSER:

Check the chiller condenser every 6 months and in accordance to the environmental conditions (humidity and dust). If dust or dirt occurs between the condenser blades clean the condenser fins using a soft brush, a vacuum cleaner or a low-pressure compressed air. Remove any dust from the cooling and electrical components.

- Accumulation of dust and grease over the condenser may cause overheating which could damage the compressor beyond repair. The condenser must always be cleaned when necessary.
- Do not use wire brushes or compressed air jets as they can damage the condenser.

4.3 DISPENSE CYCLES



NOTE

High ambient temperature may cause compressor overheating and automatic shutdown.

To reduce shut down possibility: Limit operation to a duty cycle of 2 minutes dispensing followed by 5 minutes rest.

5. Chiller Sanitisation & Cleaning

This procedure should only be carried out by persons trained by Marco or their approved distributors.

The operation of sterilisation has to be carried out every time the refrigerator is installed and:

- after every 6 months of use.
- every time the water filter is changed
- after an inoperative period of one or more weeks. If the refrigerator is installed in Hospitals, Schools, Care homes for the elderly, or Clinics, it is recommended to sterilise it every 3 months.

Use a suitable product that is both a detergent and a sanitiser, to be mixed with water in the proportions recommended by the manufacturer. We recommend you to use Bioguard Internal Watercooler Sanitiser Solution (12ml dosage). We suggest changing the product type on a regular basis, to prevent resistant bacteria. Never exceed the contact times and maximum dosage concentrations recommended by the manufacturer. Once the sanitizing fluid has flowed through and cleaned the lines, they must be thoroughly rinsed with mains water until all the sanitizer has been completely eliminated. Check the pH of the outlet water is the same as the pH of the inlet water (use litmus paper or a pH meter)

PREPARE THE COOLER FOR SANITISATION

1. Turn on water and flush at least 4 liters (1 gallon) through entire system (plain and carbonated water circuits).
2. Disconnect water line from main water supply.
3. Dispense both plain and carbonated water, until only CO2 is dispensed.
4. Close the CO2 cylinder and dispense carbonated water to remove CO2 pressure completely.

SANITISING

1. Turn off Electrical Power Supply.
2. Rotate the thermostat to the stop position to turn the compressor off.
3. Replace the filter cartridge with a sanitizing filter recommended by Marco and fill with clean water and with sanitizing fluid in the concentration and contact time recommended by the manufacturer.
4. Disconnect the water connections and connect them to the sanitization cartridge.
5. Turn on water mains and power supply mains.
6. DO NOT TURN ON COMPRESSOR SWITCH AT THIS TIME
7. Flush all lines (Cold and Sparkling) with sanitizer by pressing the buttons on the FRIIA font until you can smell the sanitizing product which may have a characteristic smell, or colour. Colorimetric test strips can also be used to make sure the entire line is filled with the sanitizing liquid.
8. NOTE: A container and drain basin will be required to collect water from the FRIIA font.
9. Be careful: respect the sanitiser concentration and contact time recommended by the manufacturer; using extra liquid will neither improve nor speed up the treatment process.

8000900	FRIIA Sanitising kit
8800125	Internal Water Cooler Sanitising Solution 1L
8000522	Chiller Best Service Cartridge

Warning : After long idle periods bacteria and germs can form if the mains power supply has been disconnected for more than 72 hours. In this case please follow a full sanitisation procedure.

5.1 CLEANING

The exterior of these machines may be cleaned with a damp cloth and a light detergent. Do not use abrasive cloths or creams, as this will spoil the finish of the machine. Do not use a water jet or spray. Beware of accidentally operating the draw off tap or push button when cleaning the front of the machine.

5.2 CAUTIONS AND SAFETY TIPS

• Risk of flooding. The hose supplied with this unit is non-toxic food quality tested to 190psi (1300 kPa). However, a hose is not a permanent connection. It is, therefore, advisable to switch off chiller and close the stopcock valve when chiller is not in use, e.g. overnight, weekends etc.

Please see Boiler Manual for descale procedure.

6. Troubleshooting

ISSUE	PROBABLE CAUSE	SOLUTION
The compressor will not start	Power failure	Check that there is voltage in the plug
	Thermostat in the off position, or set to the minimum	Check wirings and adjust the thermostat position
	The over-load protection of the compressor is faulty	Wait for compressor cool down and replace it
	The starting relay is faulty	Check wiring replace the faulty component
	The starting capacitor is faulty	Check wiring replace the faulty component
The water is cold but the appliance is operating excessively or non-stop	The compressor is faulty	Check wiring replace the faulty component
	Poor ventilation	Place the appliance away from the wall
	The condenser is dirty or covered	Clean the condenser or free it from obstructions
	Ambient temperature is higher than 32°C	It is normal that the appliance works at a continuously high room temperature
The compressor works continuously, but the water is not cold	Gas leak from the cooling system	Contact a specialized technician (refrigerator repairman) or Marco Beverage Systems
	The compressor is faulty	Check wirings and voltage on compressor terminals and replace the faulty component if needed.
Too much noise coming from the equipment, but it is working normally	The machine is not perfectly horizontal	Level the appliance using the adjustable feet
	Hoses and wirings are in contact with housing some parts inside the equipment and generate noise and vibrations.	Check and reposition hoses and wirings, making sure they do not touch any other parts.
Cold water comes out slowly or not at all	Water inlet supply shutoff valve closed or faulty electrovalves closed, water filter fouled/clogged.	Open water inlet supply line shutoff valve, check electrovalves and anti-flooding device replace electrovalves ; replace filter or cartridge.
	Low pressure of the inlet net water	Take steps to increase the net pressure (e.g. booster pump)
	The thermistor is out of tolerance range or defective	Turn machine off and wait for ice to melt, replace thermistor

ISSUE	PROBABLE CAUSE	SOLUTION
Too low CO ₂ volume	CO ₂ pressure too low	Restore correct CO ₂ pressure (typically about 4 bar / 60 psi)
	CO ₂ cylinder empty	Replace CO ₂ cylinder
	Water temperature too high because cooling capacity is exceeded by over drawing	See refrigeration/equipment specifications vs. volume requirements and reduce amount of glasses taken per given time of install higher volume unit.
	Air trapped inside the carbonator	Open carbonator vent check valve, pulling ring.
CO ₂ only flows out from faucet	Carbonator Electrode connection to wiring harness defective, loose electrical connection and/or open circuit	Tighten connection, repair carbonator wiring harness connection and check electrode connection at E.C.U.
	The carbonation pump turns continuously	No water is entering or the water filter is blocked or Hoses and pipe fittings into the carbonator are obstructed. Disassemble and clean it.
	Check valve on carbonator water inlet failed open	Verify correct behavior of the non-return (check valve) assembled on the carbonator water inlet.
	Inoperable water pump/ motor.	Check for proper line voltage on component terminals. Replace water pump/ motor if defective.
	Electronic Control Unit (E.C.U.) defective.	Replace E.C.U. assembly.
	E.C.U. in timeout (> 240" continuous operation)	Reset Timeout protection switching off equipment and waiting 60" before repower it.
Short cycling of water pump motor	Carbonator Electrode connection to wiring harness defective or reversed.	Repair carbonator wiring harness connection and check electrode connection at E.C.U.
Continuous dripping from the outlets	Few drops, mainly after soda dispensing is normal. If dripping is continuous faucet or internal electrovalve could be dirty.	Contact Marco service
Still water comes out carbonated	Internal check valve could be dirty.	Disassemble check valve and clean it. Replace if needed.

7. FRIIA INSTALLATION GUIDE

Font Positioning

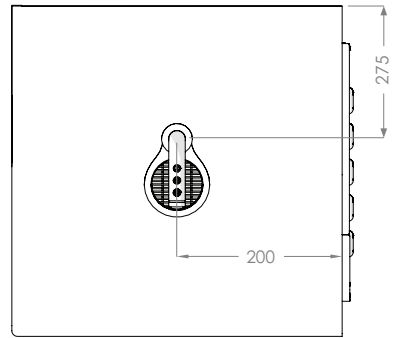
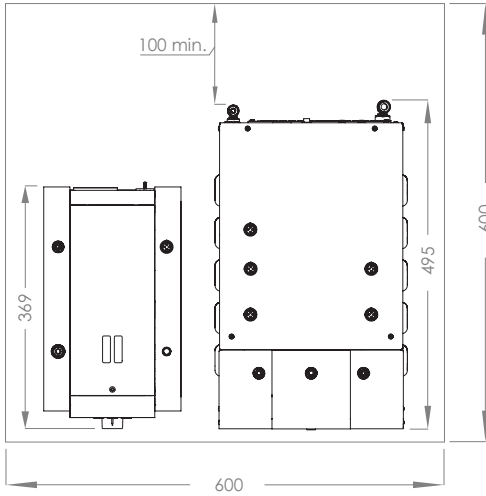
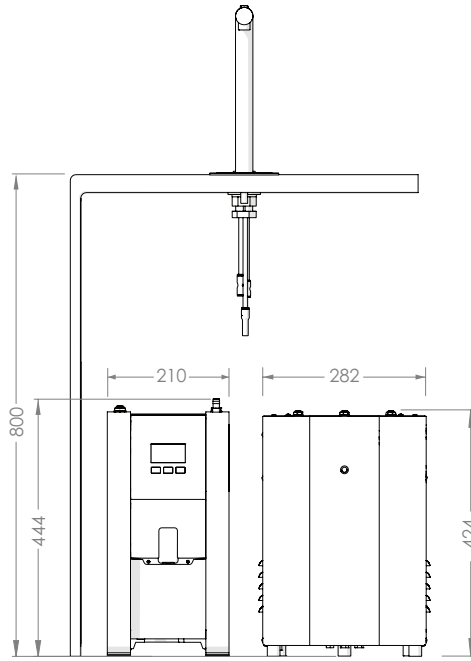

FRIIA Font Counter Cut Out

Check scale of template before cutting.

NOTE: Check scale of template before cutting. Scale should be 1:1

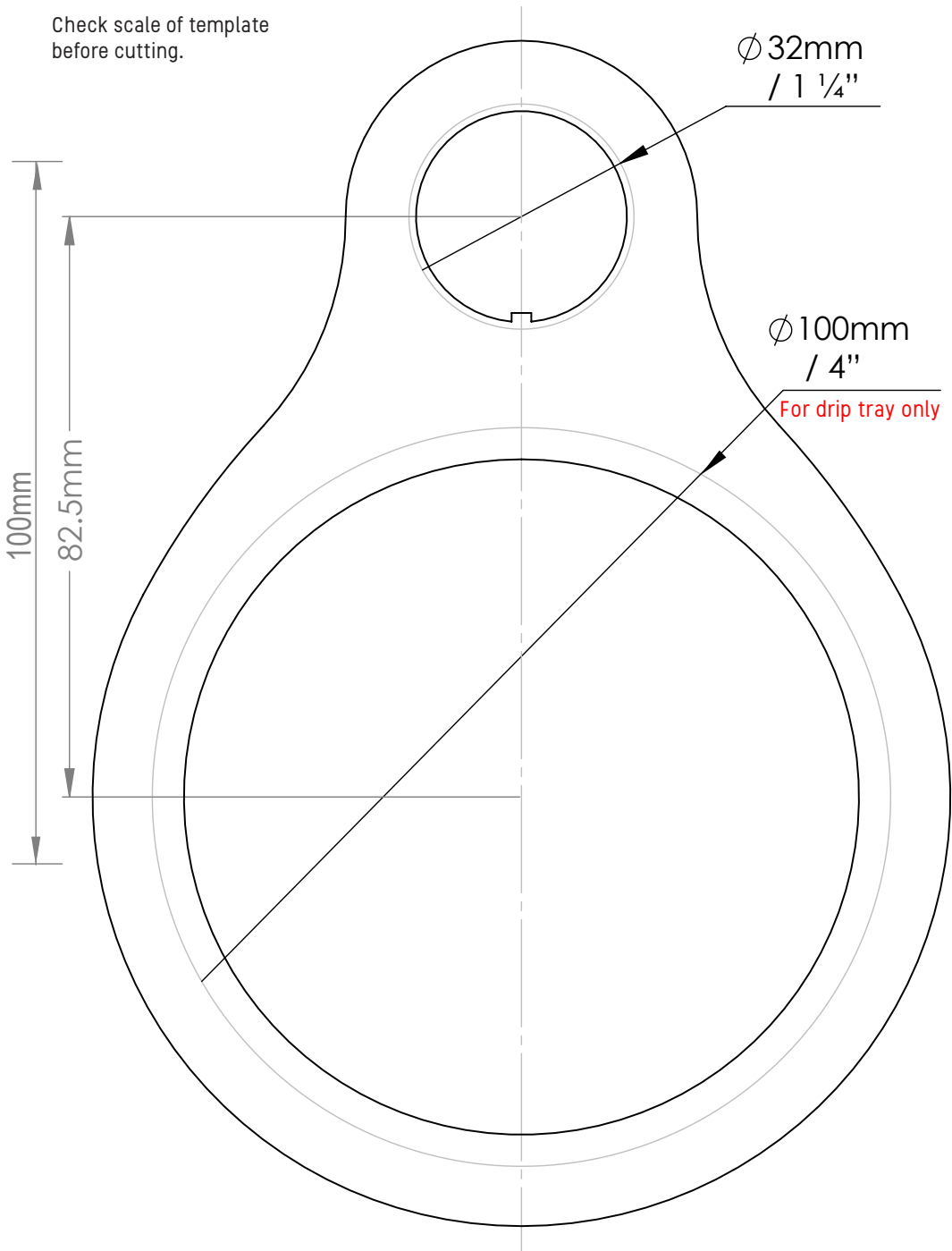

Ø 32mm
/ 1 1/4"

Ø 100mm
/ 4"
For drip tray only

100mm
82.5mm

Recommended Plumbing

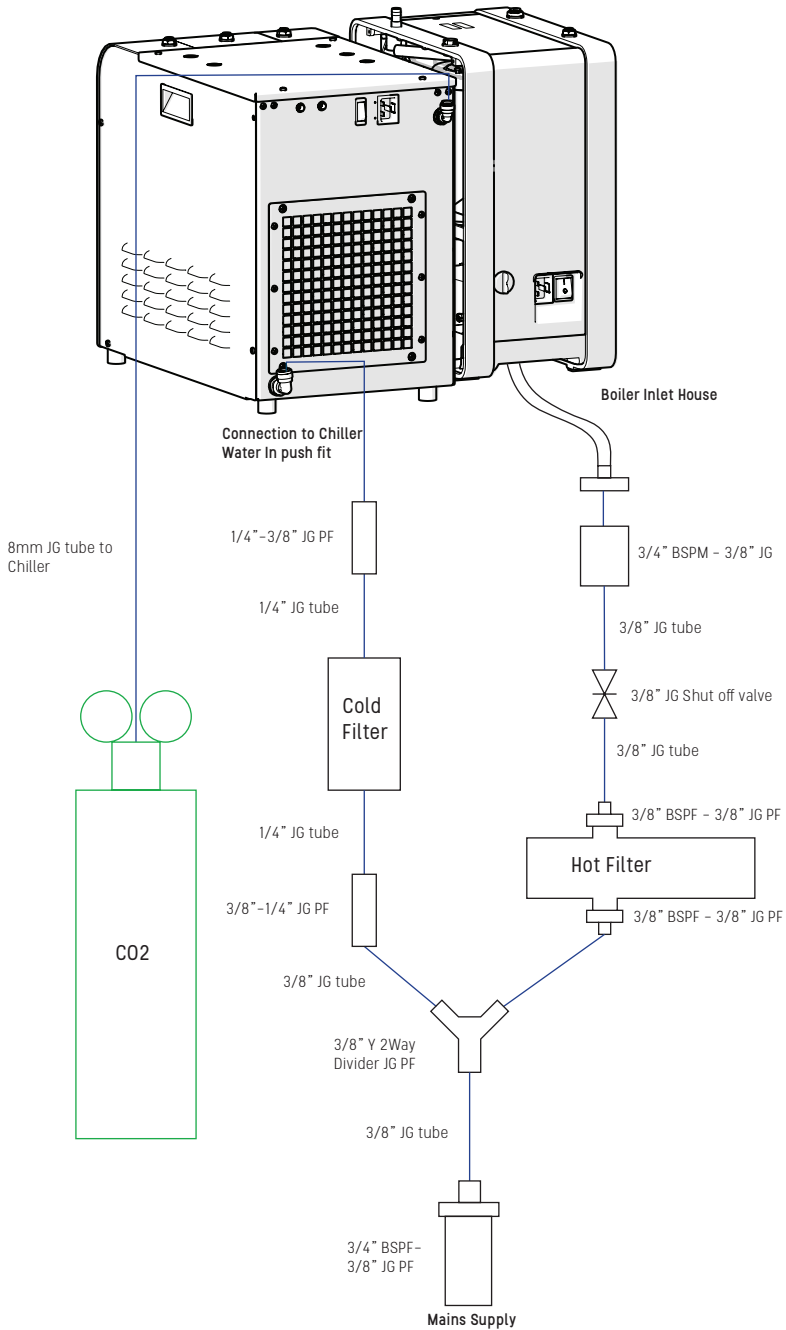

Chiller Installation 230V

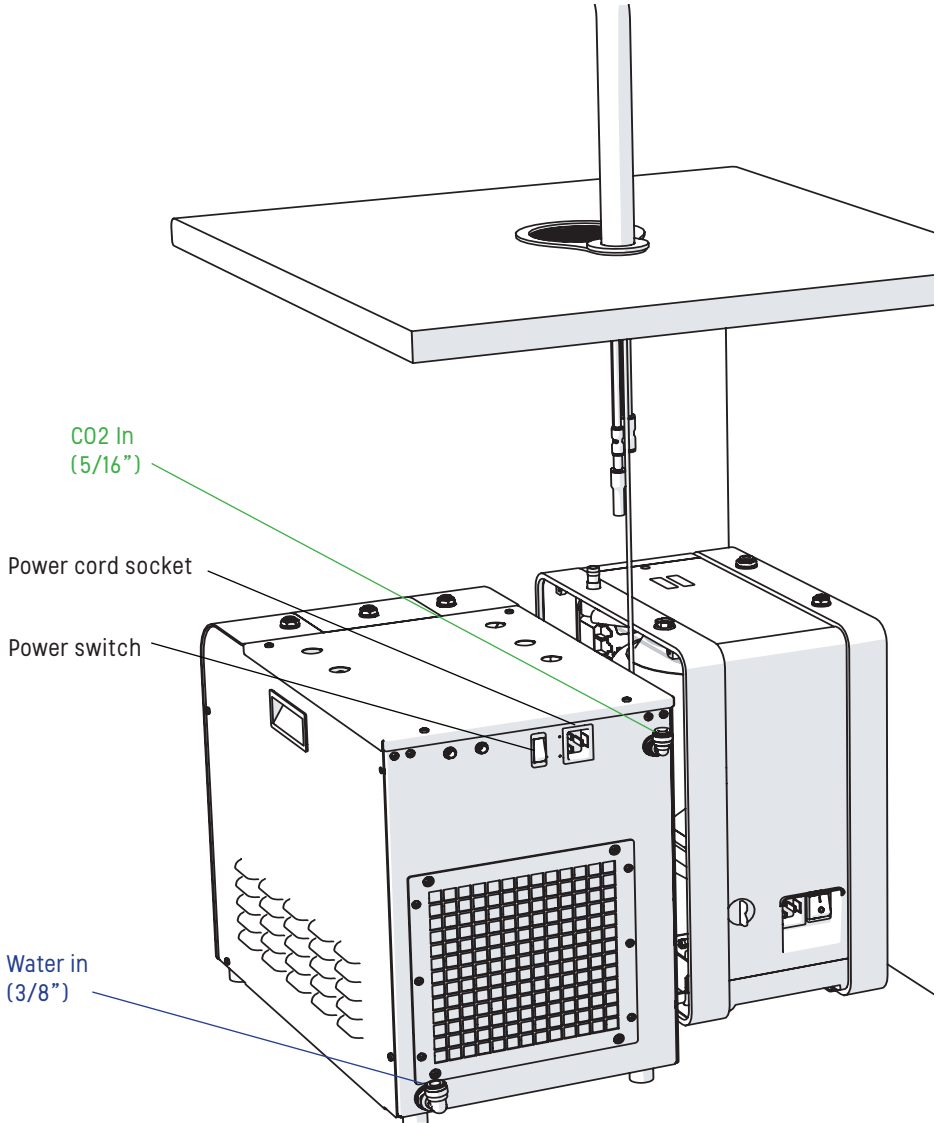

Boiler Installation

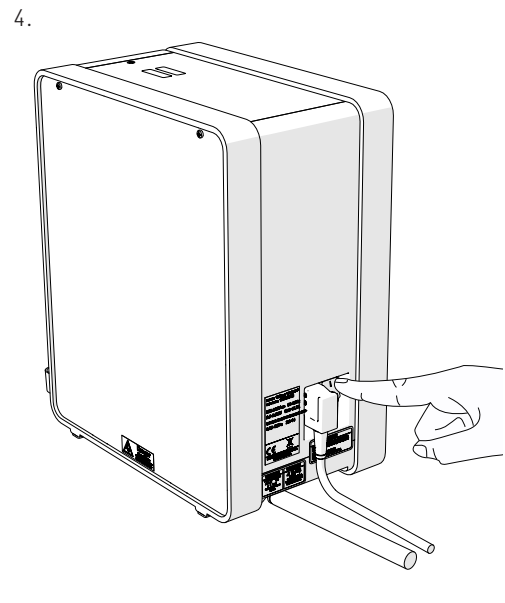
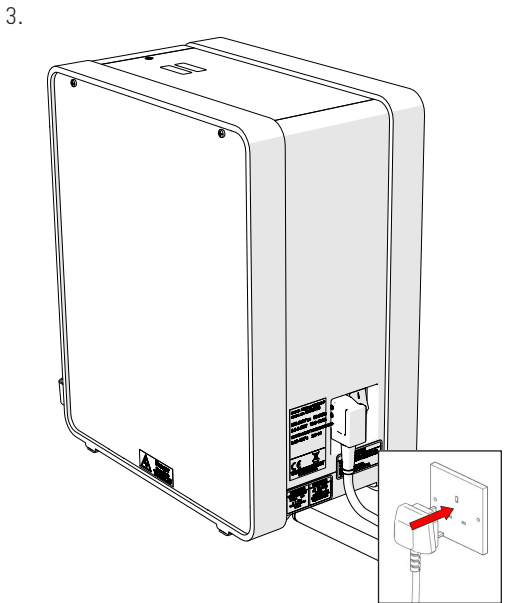
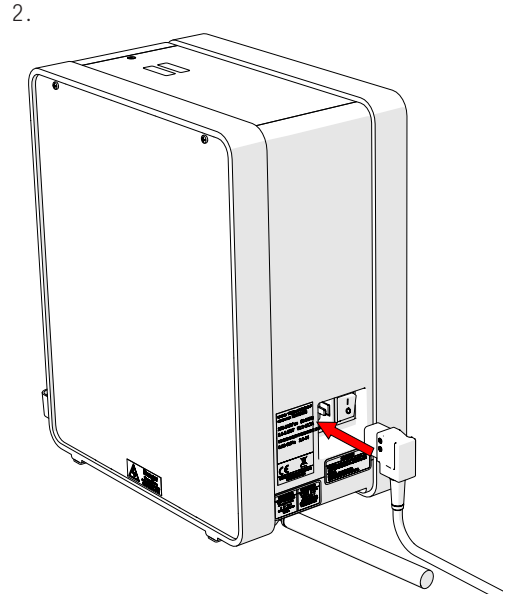
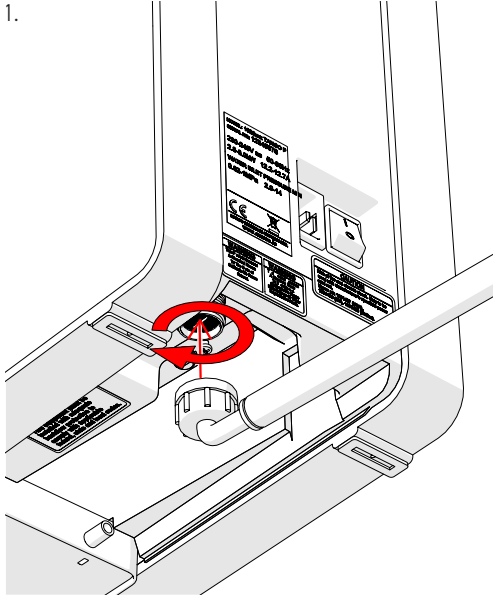

Font Installation

1. No Drip Tray

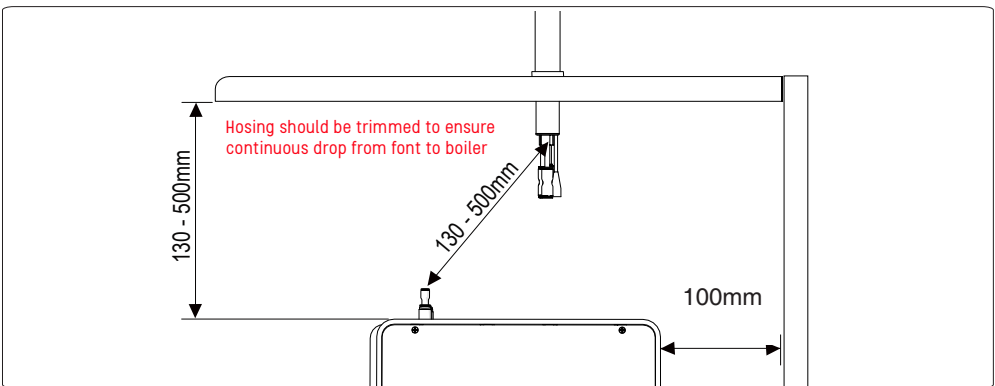
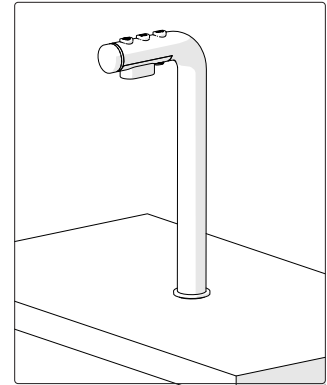
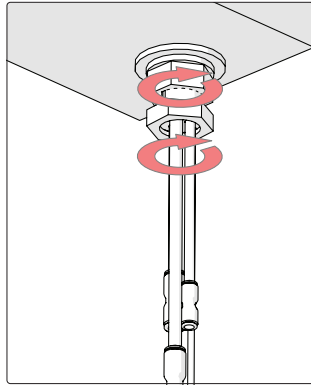
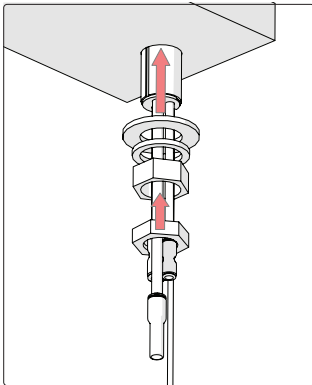
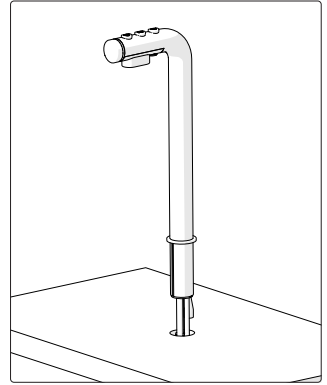
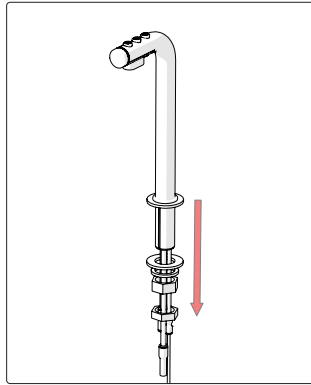
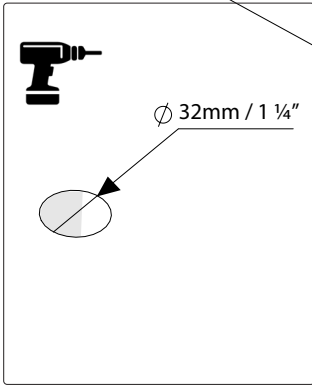

Font Installation

2. Drip Tray (sold separately p/n. 2300268)

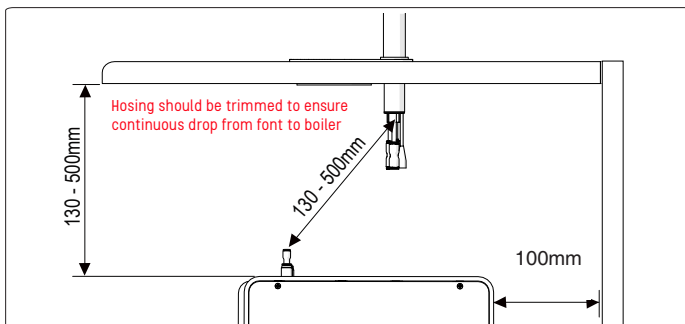
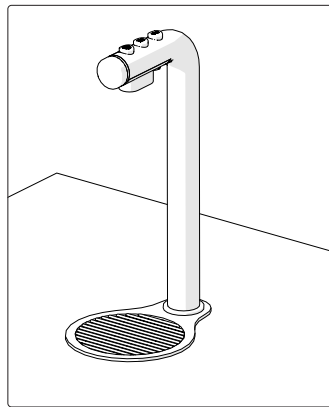
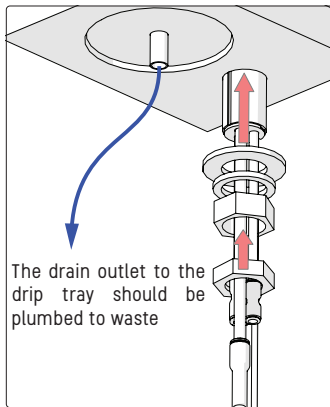
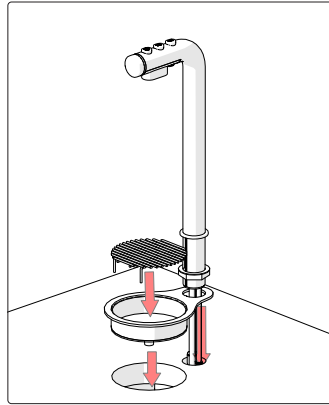
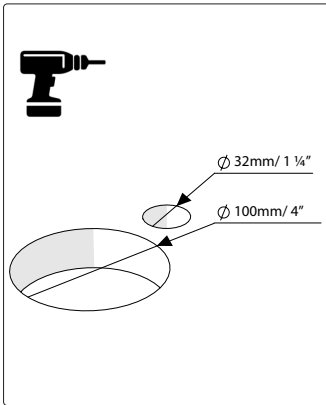

Connecting Hoses

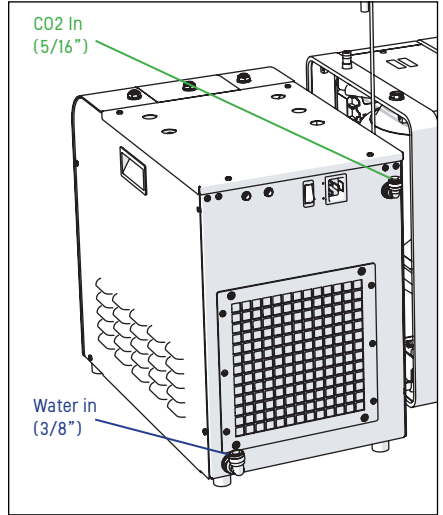
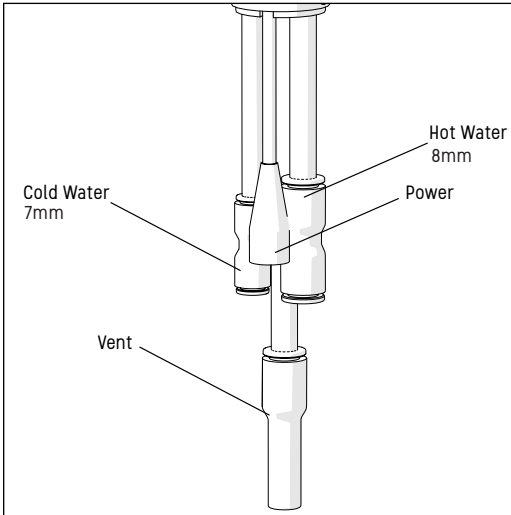
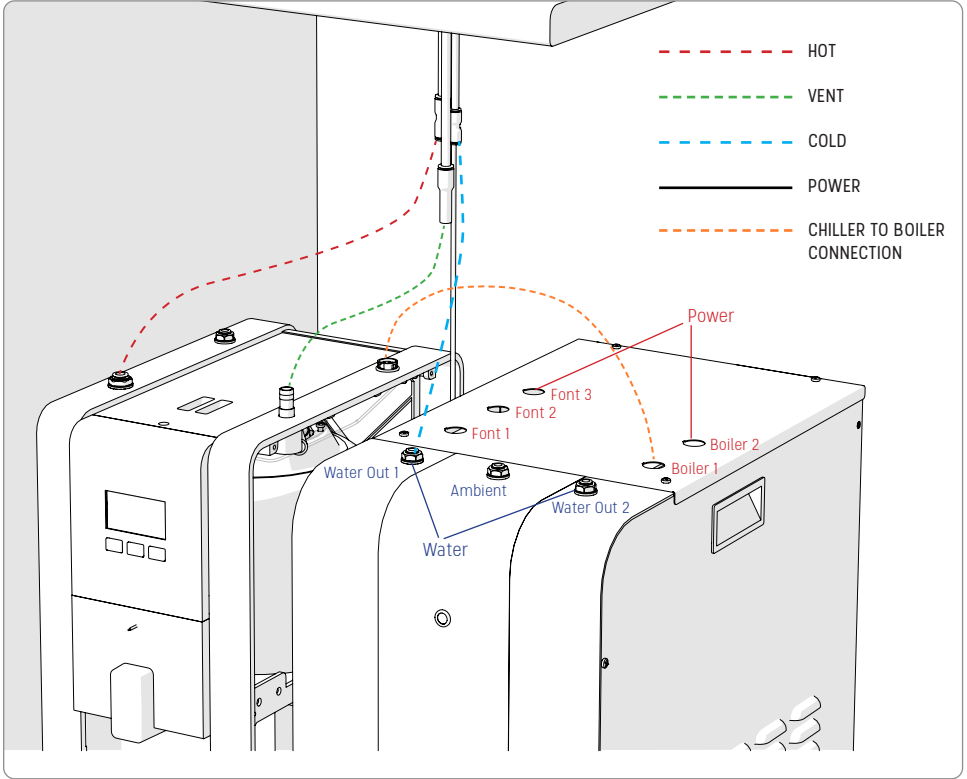

Software Setup

Diagram of Parts	
1.	Hot Connection
2.	Vent
3.	Wiring Connection
4.	Access Panel
5.	Screen
6.	Push Buttons
7.	Service Panel

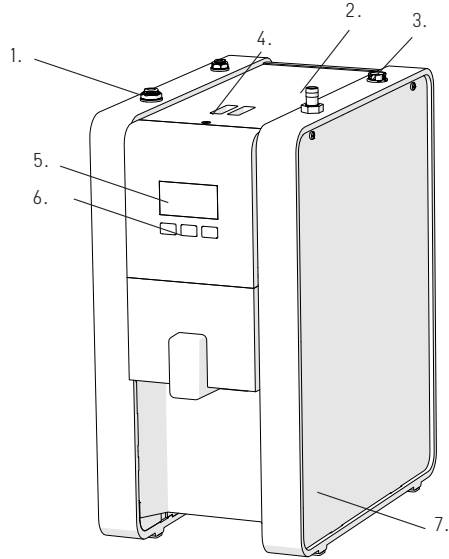

Set Up Single Button Font (default is 3 button font)

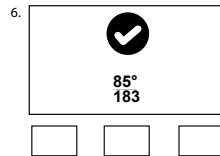
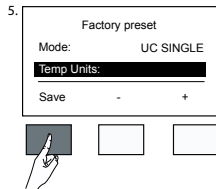
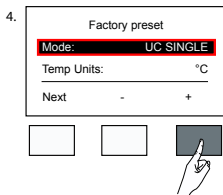
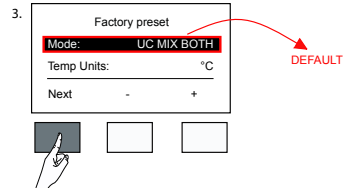
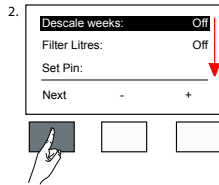
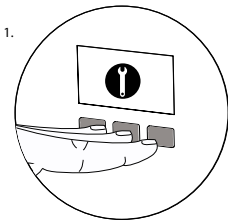

Cabinet Ventilation

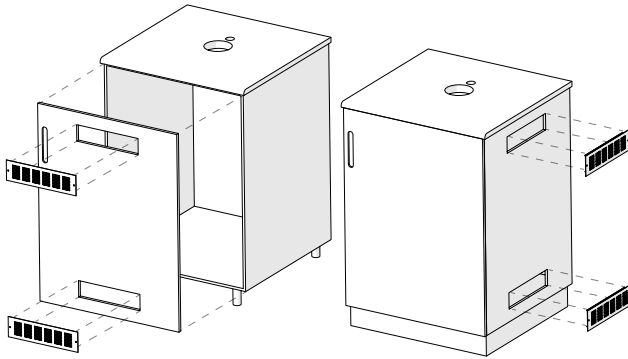

Front ventilation

Ventilation grilles cut out of standard cabinet door.

Side ventilation

Ventilation grilles cut out of standard 600mm cabinet. Grilles may be fitted on either side as long as they ventilate into an open unobstructed area.

Please Note:

In all cases remove the back panel from the cabinet.

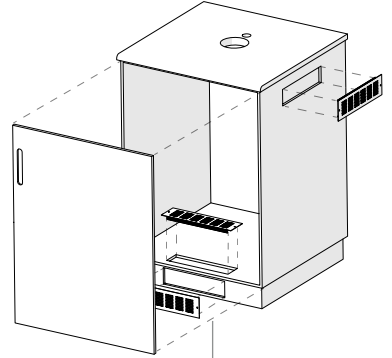

Base ventilation

Ventilation grilles cut in base panel and base plinth, a grille must also be cut out at the top of the cabinet.

The cabinet may be ventilated in many ways provided there are cut outs placed near the base and another near the top of the cabinet to take advantage of natural circulation.

Cabinet temperature: Max 35°C, if more air is not being evacuated efficiently it may cause cooling issues or possibly damage the equipment.

Grille dimensions

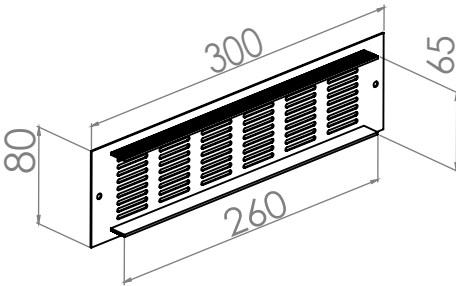

Cut out for standard 600mm door

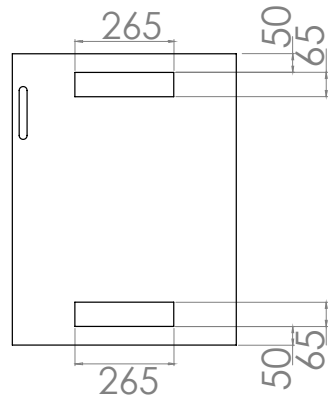

Fan Installation

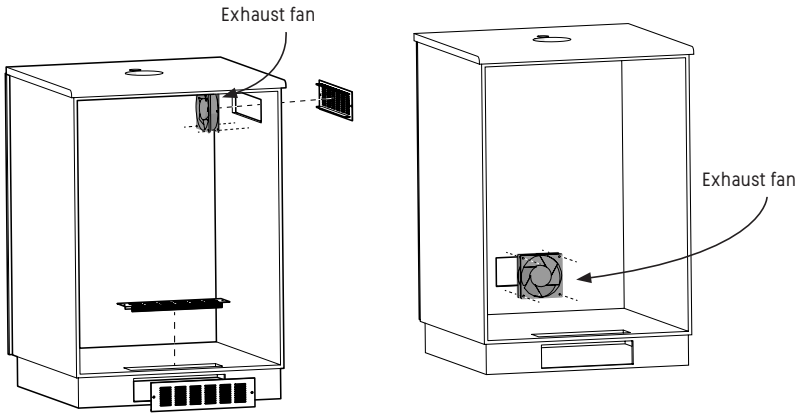
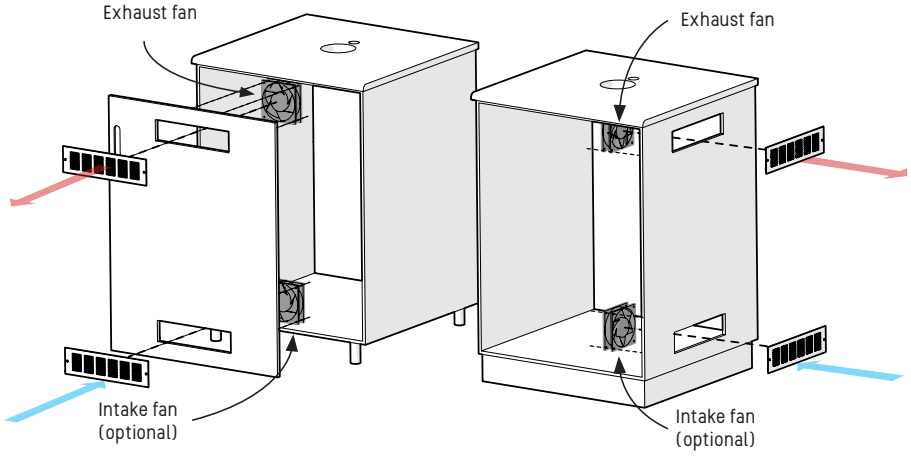



Marco Beverage Systems Limited,
74 Heather Road,
Sandyford Business Park,
Dublin 18,
Ireland
Tel: 00353 (0) 1 295 2674
Email: sales@marcobeveragesystems.com

